

Surname						Other Names					
Centre Number						Candidate Number					
Candidate Signature											

Leave blank
-------------

General Certificate of Education  
 June 2002  
 Advanced Level Examination



**COMPUTING** **CPT4**  
**Unit 4 – Processing and Programming Techniques**

Monday 17 June 2002 Morning Session

**No additional materials are required.**  
 You may use a calculator.

For Examiner's Use			
Number	Mark	Number	Mark
1			
2			
3			
4			
5			
6			
7			
8			
9			
10			
Total (Column 1)	→		
Total (Column 2)	→		
TOTAL			
Examiner's Initials			

Time allowed: 1 hour 30 minutes

**Instructions**

- Use blue or black ink or ball-point pen.
- Fill in the boxes at the top of this page.
- Answer **all** questions in the spaces provided. All working must be shown.
- Do all rough work in this book. Cross through any work you do not want marked.

**Information**

- The maximum mark for this paper is 65.
- Mark allocations are shown in brackets.
- You will be assessed on your ability to use an appropriate form and style of writing, to organise relevant information clearly and coherently, and to use specialist vocabulary, where appropriate.
- The degree of legibility of your handwriting and the level of accuracy of your spelling, punctuation and grammar will also be taken into account.

Answer **all** questions in the spaces provided.

1 It has been decided to re-write an existing system. What factors should be considered when deciding on the programming language to use? Give **three** factors, and explain why each is important.

Factor 1.....

Explanation .....

.....

Factor 2.....

Explanation .....

.....

Factor 3.....

Explanation .....

.....

(6 marks)

2 For the expression  $3+x$  the binary tree stores + at the root, 3 at the left hand node and x at the right hand node. If the nodes of this tree are printed as the tree is traversed, what will be printed when the traversal is

(a) pre-order; .....

(b) in-order; .....

(c) post-order? .....

(3 marks)

6

3

3 (a) What is a *register* in a computing context?

.....  
.....  
(1 mark)

(b) Give **one** reason for using general purpose registers rather than main memory.

.....  
.....  
(1 mark)

(c) Some registers are used in the processor for a specific purpose. Name **three** such registers and explain the purpose of each one.

1 Name.....  
Purpose .....

2 Name.....  
Purpose .....

3 Name.....  
Purpose .....

(3 marks)

5

**TURN OVER FOR THE NEXT QUESTION**

**Turn over ►**

4 A procedure to process an array of numbers is defined as follows.

```

Procedure P(Number)
  Repeat
    X ← StartofArray
    Flag ← False
    Repeat
      If Number(X) > Number (X+1)
        Then
          Begin
            Temp ← Number(X)
            Number (X) ← Number (X+1)
            Number(X+1) ← Temp
            Flag ← True
          End
        X←X+1
      Until EndofArray
    Until Flag = False
  Endproc

```

The array number, containing 17, 11, 21, 9, 23, 15, is to be processed by this procedure.

(a) List the array after the outer Repeat loop has been executed once.

.....

.....

.....

.....

.....

.....

.....

.....

.....

.....

.....

.....

(2 marks)

(b) What algorithm does the procedure P describe?

.....

(1 mark)

(c) What is the purpose of Flag in this procedure?

.....

(1 mark)

5 The following data is input to a program, in alphabetical order, and is stored.

Anne  
Bob  
Claire  
Dean

(a) Draw a diagram to show how this data is stored for:

(i) a stack;

(ii) a queue.

*(4 marks)*

(b) One item is retrieved from these data structures for processing, and Eden is input.

Draw the diagrams of this new situation for:

(i) the stack;

(ii) the queue.

*(3 marks)*

(c) Why are queues in computer systems usually implemented as circular queues?

.....  
.....  
.....  
.....

*(2 marks)*

**Turn over ►**

- 6 A process can only begin if bits 0 (least significant bit) and 4 of register A are set to 1, and bits 2 and 3 are set to 0. The status of the other four bits has no effect on the process.

Bits	7	6	5	4	3	2	1	0
				1	0	0		1

Write the key assembly language instructions to check whether the process can take place.

(5 marks)

- 7 A supermarket has a section labelled 'Bottled Water'. Bottled water comes as 'still bottled water' or 'carbonated bottled water'.

In an object-oriented program, 'bottled water', 'still bottled water' and 'carbonated bottled water' are three defined *classes*. The classes 'still bottled water' and 'carbonated bottled water' are related, by single *inheritance*, to 'bottled water'.

(a) What is meant here by

(i) class? .....

.....

(ii) inheritance? .....

.....

(2 marks)

(b) Draw an inheritance diagram for the given classes.

(3 marks)



(c) Give **three** advantages of the object-oriented approach to programming over a structured approach.

- 1 .....
- .....
- 2 .....
- .....
- 3 .....
- .....

(3 marks)

8 (a) A binary pattern might represent a decimal *integer* or a decimal *real number*. In a computing context, give an example of

- (i) a decimal integer.....
- (ii) a decimal real number.....
- (iii) The binary data 00110111 represents an unsigned real number in fixed point form, with the binary point between bits 1 and 2, e.g. 1101.11. Convert this number into decimal, showing all your working.

(4 marks)

(b) Convert the binary data 10110111 00111110 into hexadecimal.

(1 mark)

(c) Give **one** example of where hexadecimal numbers are used, and explain why they are used here rather than binary numbers.

- .....
- .....
- .....
- .....

(2 marks)

Turn over ►

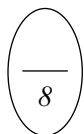

9

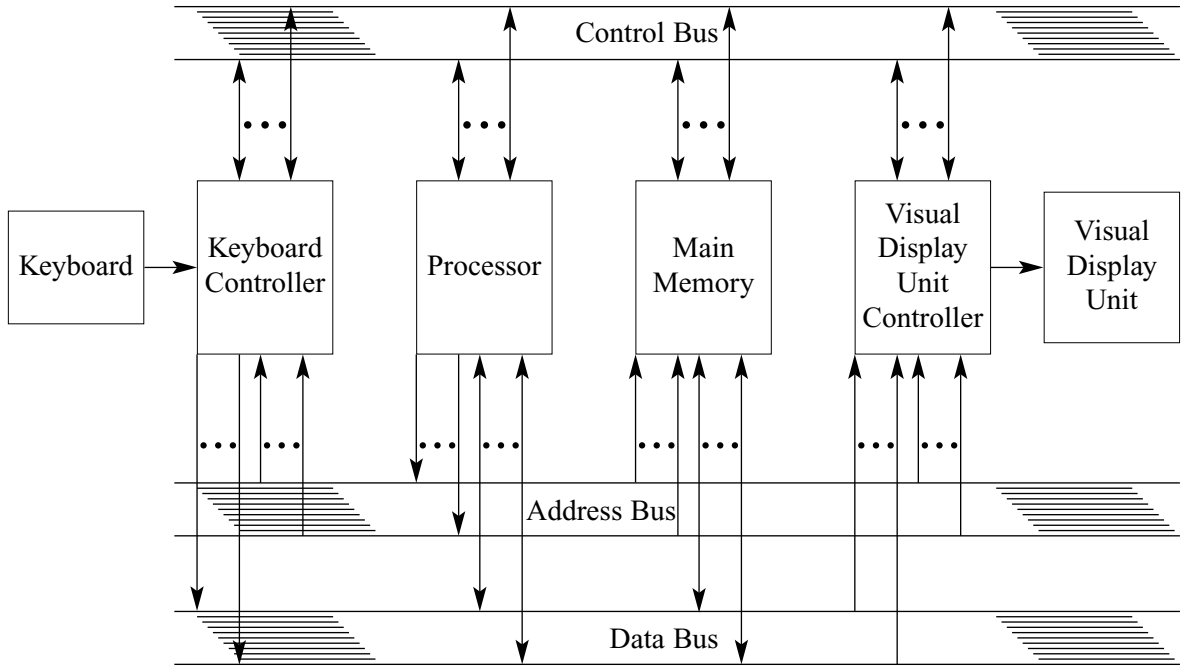

The figure above is a block diagram showing the bus architecture of a typical microcomputer. A device controller is a hardware unit which is attached to the bus system of the computer to provide a hardware interface between a computer and a device such as a keyboard.

(a) Why are devices **not** connected directly to the processor?

.....  
 .....

(2 marks)

(b) Name **one** other device controller which may be found in a typical microcomputer.

.....  
 .....

(1 mark)

(c) The data bus carries data in both directions. Explain why the address bus only carries addresses in one direction.

.....  
 .....

(2 marks)

(d) Name and describe the function of **two** signal lines that are usually present in a control bus.

1. Name.....

Function .....

.....

2. Name.....

Function .....

.....

*(4 marks)*

9

**TURN OVER FOR THE NEXT QUESTION**

**Turn over ►**

10 Among the features of the memory management part of a *multitasking* (multiprogramming) Operating System are *Dynamically Linked Libraries* (DLLs).

(a) What does the term multitasking mean when applied to an operating system?

.....  
.....  
.....

(2 marks)

(b) What are Dynamically Linked Libraries (DLLs)?

.....  
.....  
.....

(2 marks)

(c) Give **one** reason for using a DLL.

.....  
.....

(1 mark)

(d) A running process in a multitasking environment requires a dynamically linked library which is not in main memory. Explain the likely sequence of process states (runnable, running and suspended) that the process will now pass through. Assume there are **three** processes in all.

.....  
.....  
.....  
.....  
.....  
.....

(4 marks)

**END OF QUESTIONS**



**THERE ARE NO QUESTIONS PRINTED ON THIS PAGE**

**THERE ARE NO QUESTIONS PRINTED ON THIS PAGE**